

# PIPEFITTER'S SQUARE

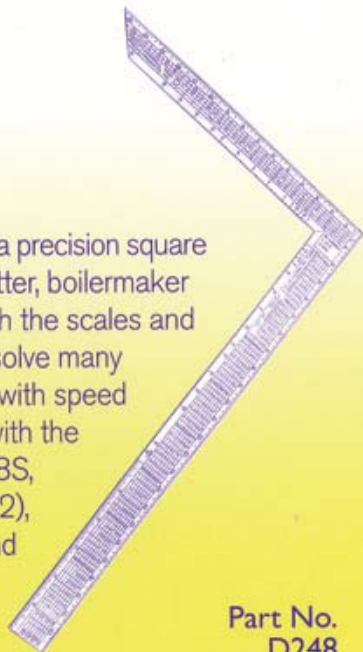

The Pipefitter's Stainless Steel Square is a precision square that was designed for the welder, pipefitter, boilermaker or layout man. Once you are familiar with the scales and table of this square, you will be able to solve many problems in pipefitting and layout work with speed and accuracy. The D248 can be used with the Small or Large Square Positioner (D238S, D243L, Protractor Square Holder (D242), Small or Large Pipefitter's Protractor and Square Set (239S, D239L).



Part No.  
D248

**"More Ways to Help Welders and Pipefitters"**

# TABLE OF CONTENTS

	<b>PAGE</b>
INTRODUCTION	1
<b><u>CHARTS</u></b>	
CHART NO.1 Standard Weld Tee	2
CHART NO.2 Standard Weld Ell	2
CHART NO.3 150# Weld Neck Flange	3
CHART NO.4 300# Weld Neck Flange	3
CHART NO.5 O.D. OF 150# Flange	4
CHART NO.6 O.D. OF 300# Flange	4
CHART NO.7 Diameter of 150# Slip Blind	5
CHART NO.8 Diameter of 300# Slip Blind	5
CHART NO.9 Circumference & 1/8 Circumference of Pipe	6
CHART NO.10 Bolt Chart - 150# Flange	7
CHART NO.11 Bolt Chart - 300# Flange	7
CHART NO.12 Tangent Chart	8
CHART NO.13 Inches Divided into Feet	9
CHART NO.14 "X" Dimension of Standard Chart	10
CHART NO.15 Millimeter Chart	10
CHART NO.16 Finding Degrees Off Vertical & Horizontal	11
CHART NO.17 Inch Divided into Sixteenths	12
CHART NO.18 Decimal Equivalent Chart	12
CHART NO.19 90° Saddle	13
CHART NO.20 Laying out for a Base Ell	14
CHART NO.21 ARC 90°	15
CHART NO.22 1/4 Marks on Chart	16

## TABLE OF CONTENTS

### EXAMPLES

EXAMPLE NO. 1	Finding Cut-Back for any Miter	17
EXAMPLE NO. 2	Converting Slope (Inches Per Foot to Degree)	17
EXAMPLE NO. 3	Laying Out Laterals (Miter Method)	18
EXAMPLE NO. 4	Solving Triangles & Offsets	18
EXAMPLE NO. 5	Laying Out Laterals	19
EXAMPLE NO. 6	For Parallel Piping	23
EXAMPLE NO. 7	Rolling Offsets	24
EXAMPLE NO. 8	Preparing Pipe for Ordinate Lengths	26
EXAMPLE NO. 9	Applying Ordinate Lengths to Pipe (Radial Cuts)	27
EXAMPLE NO. 10	Applying Ordinate Lengths to Pipe (Miter Method)	28
EXAMPLE NO. 11	To Find Center to End of Bends & Fitting	29
EXAMPLE NO. 12	Laying Out Angles	29
EXAMPLE NO. 13	Laying Out a Y	30

# PIPEFITTER'S SQUARE

## INSTRUCTIONS

No. 248

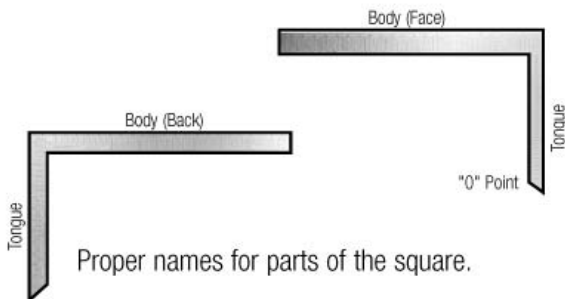
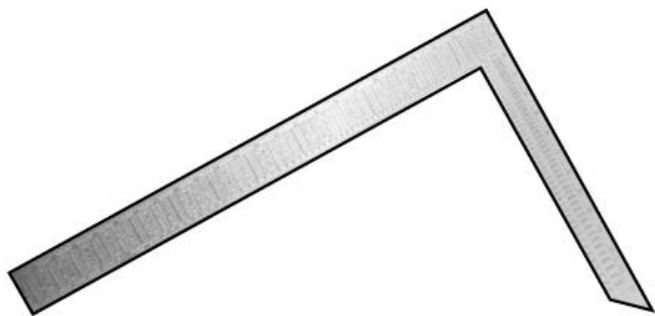

Copyright © Mathey Dearman, Inc.  
Printed in the USA - April 2002

## CHART NO. 1

### WELD TEE CENTER TO END DIMENSION

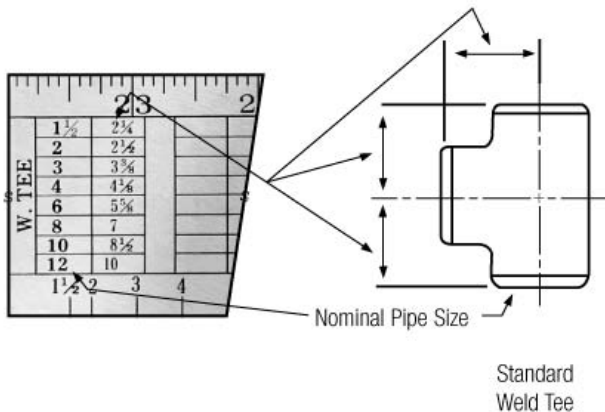

## CHART NO. 2

### STANDARD 45° WELD ELL CENTER TO END DIMENSION

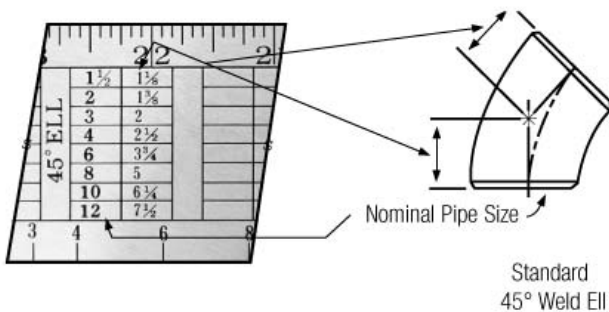

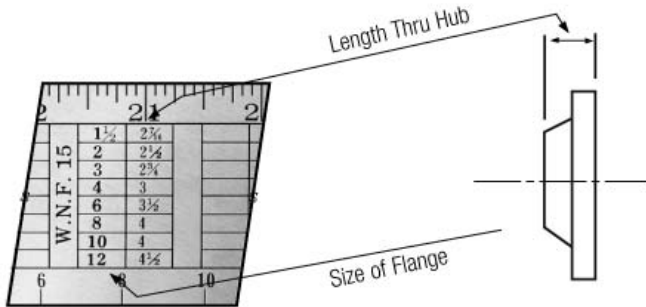
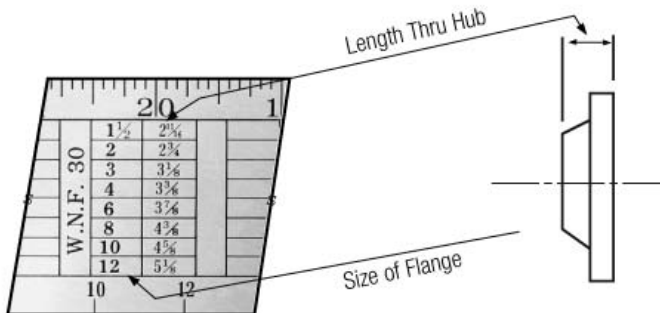
**CHART NO. 3****150# WELD NECK FLANGE  
LENGTH THRU HUB****CHART NO. 4****300# WELD NECK FLANGE  
LENGTH THRU HUB**

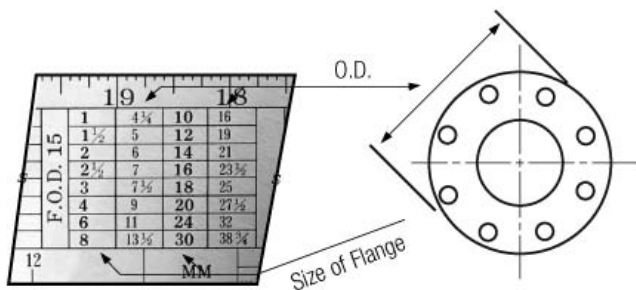
**CHART NO. 5****OUTSIDE DIAMETER OF 150# FLANGE**

This gives outside diameter of 150# Flanges.

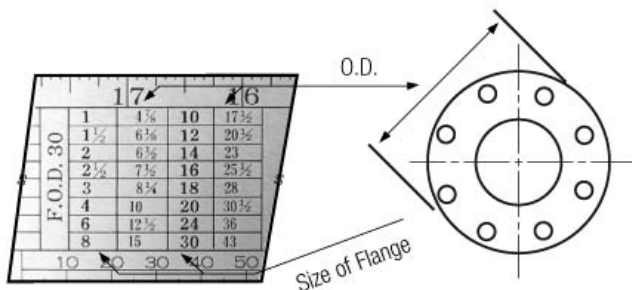
**CHART NO. 6****OUTSIDE DIAMETER OF 300# FLANGE**

This gives outside diameter of 300# Flanges.

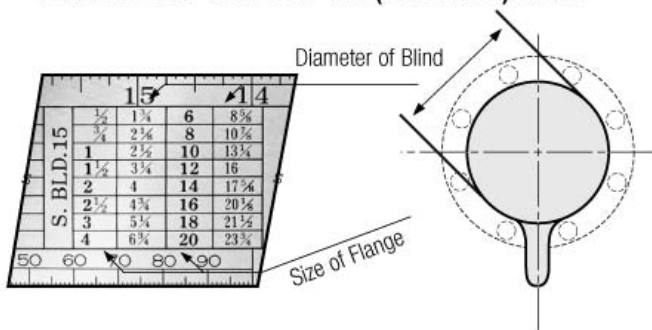
**CHART NO. 7****DIAMETER OF 150# SLIP OR (PAN-CAKE) BLIND**

Bolt Circle of Flange may be found by adding the diameter of one bolt hole to the diameter of Blind. Gasket O.D. is found by adding 1/8" to diameter of Blind.

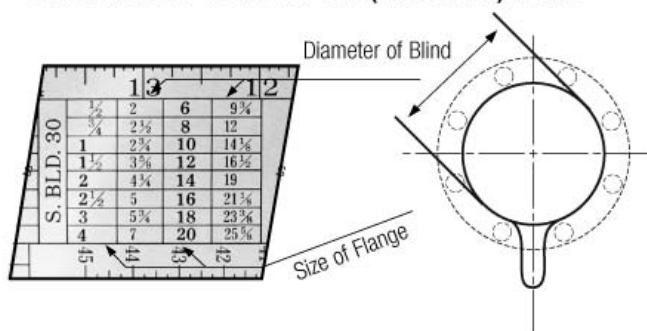
**CHART NO. 8****DIAMETER OF 300# SLIP OR (PAN-CAKE) BLIND**

Bolt Circle of Corresponding Flange may be found by adding the diameter of one bolt hole to the diameter of Blind. Gasket O.D. is found by adding 1/8" to diameter of Blind.

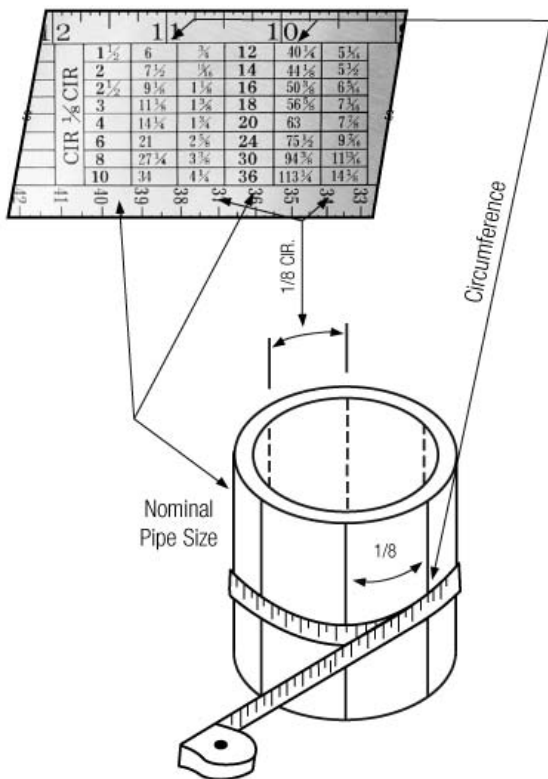

**CHART NO. 9****CIRCUMFERENCE 8, 1/8 CIRCUMFERENCE OF PIPE**

First number in line is pipe size. Second number is circumference of pipe in inches. Third number is 1/8 circumference of pipe.



## CHART NO. 12

**TANGENT CHART FROM 1° TO 45° OPPOSITE EACH DEGREE. YOU WILL FIND THE TANGENT.**

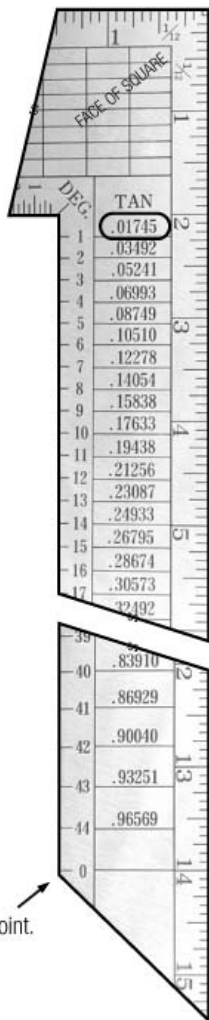

← X Degree X Radius =  
Arc or Length of Bend

### **Example:**

For 20° bend on 6" radius

$$20 \times 6 = 120$$

$$.01745 \times 120 = 2.094$$

2.094 = Length of Arc or Length of Bend.

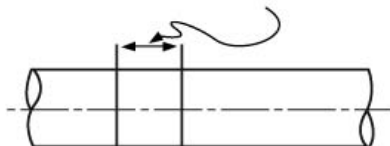

Layout Completed

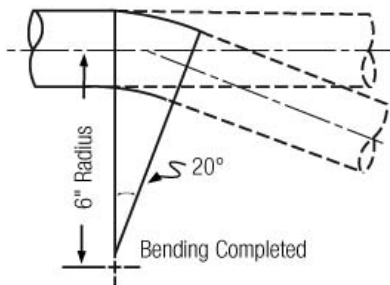

Bending Completed

"0" Point.

## CHART NO. 13

INCHES DIVIDED  
INTO FEET

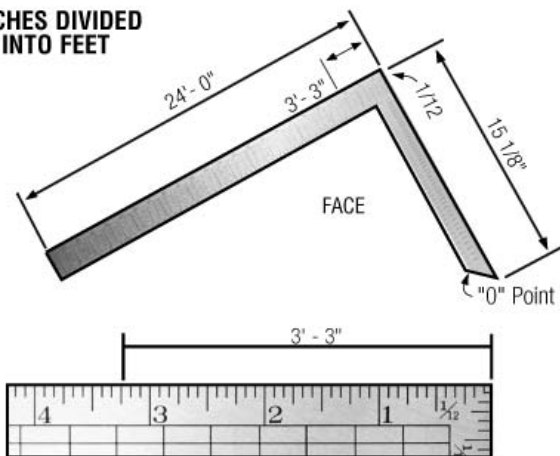
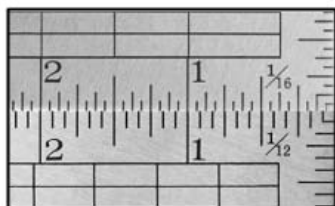

FIGURE 1

This scale is divided into inches and 12ths of an inch, which may be used as feet and inches when scaling work down.

**Example:** Figure 1.  $3 \frac{1}{4}" = 3' - 3"$



To convert sixteenths to twelfths, lay rule on square as shown.

## CHART NO. 14

### "X" DIMENSION OF STANDARD PIPE

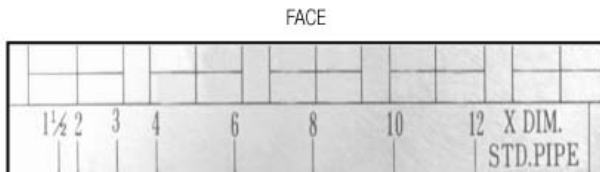

This scale shows the dimension of "X".

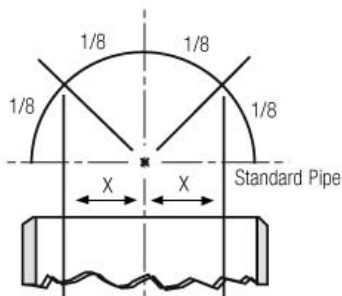

Used for layout work.

## CHART NO. 15

### MILLIMETER SCALE 0 TO 100

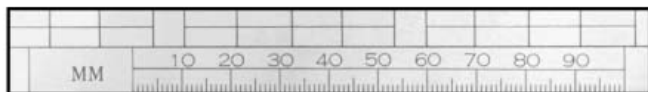

To convert inches into  
MM or MM into inches.

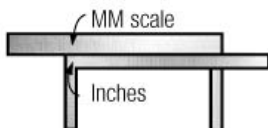

# CHART NO. 16

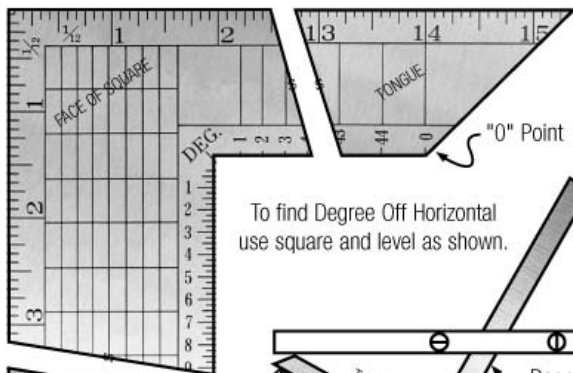

To find Degree Off Horizontal use square and level as shown.

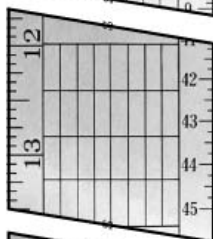
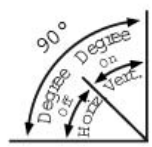
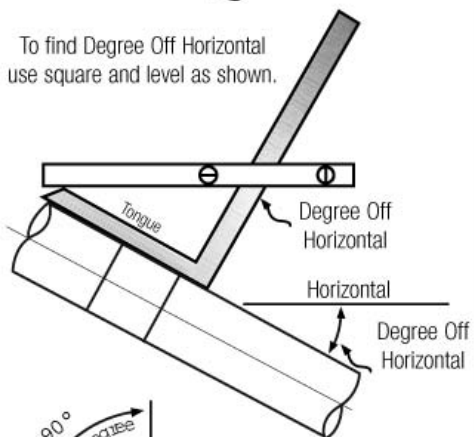

To find Degree Off Vertical use squares and level as shown.

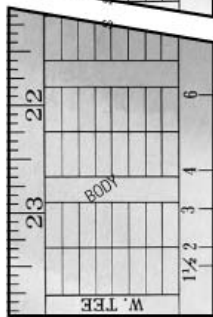
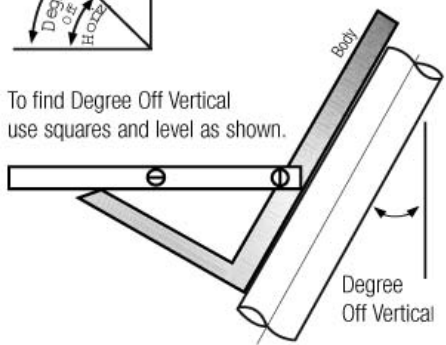

**CHART NO. 17**

FIGURE 2

This scale is divided into 16 parts which represent parts of an inch. Each mark to be  $\frac{1}{16}$ ". Therefore (figure 2.) would show - 2 inches and 3 sixteenths ( $2 \frac{3}{16}$ ").

**CHART NO. 18**

	22		23	
	$\frac{1}{16}$	.0625	$\frac{1}{16}$	.5625
	$\frac{2}{16}$	.125	$\frac{2}{16}$	.625
	$\frac{3}{16}$	.1875	$\frac{3}{16}$	.6875
	$\frac{4}{16}$	.25	$\frac{4}{16}$	.75
	$\frac{5}{16}$	.3125	$\frac{5}{16}$	.8125
	$\frac{6}{16}$	.375	$\frac{6}{16}$	.875
	$\frac{7}{16}$	.4375	$\frac{7}{16}$	.9375
	$\frac{8}{16}$	.5		
	5			

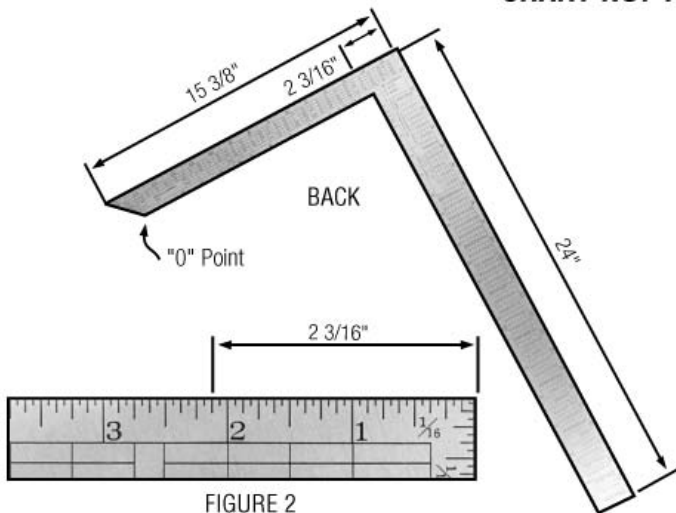
Fraction of an inch decimal equivalent.





## CHART NO. 20

### LAYING OUT THE PIPE FOR A BASE ELL

All Cuts Are Radial.

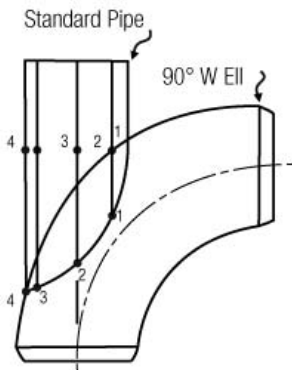

#### **Example:**

1. To saddle 2" pipe on 4" Ell, on the top line you find the No. 2 which means 2" pipe.
2. Follow the top line to 4" Ell. Here you find the following: 5/16, 1 1/4, 2 & 2 1/4. These are applied to the pipe as shown above - 5/16, 1 1/4, 2-2; 2, 3-3; and 2 1/2, 4-4.

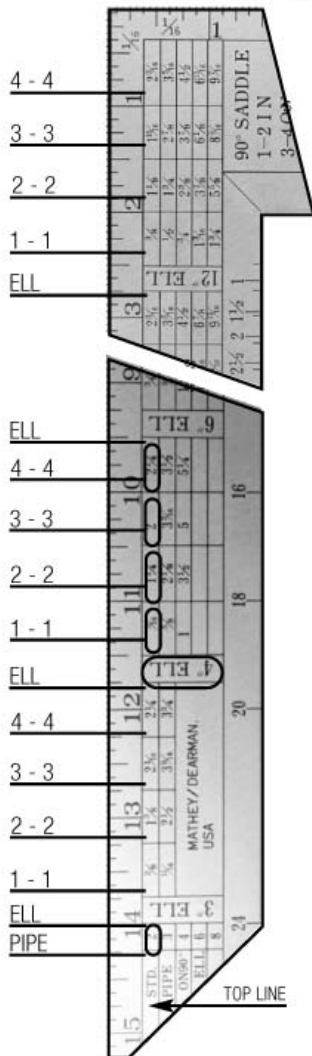

## CHART NO. 21

### ARC 90°

ARC LENGTH FOR A GIVEN RADIUS OF A 90° BEND

**Example:**

To bend pipe 90° on a 3" radius, lay scale on pipe and mark 0 and 3. This will be Arc; or Length of Bend. For 45° bends use 1/2 of Arc. For 30° bends use 1/3 of Arc.

When radius is greater than scale use multiples of scale.

**Example:**

If you want 9" radius, mark 0 and 6, then move scale with 0 on 6 and mark 3 (equals 9).

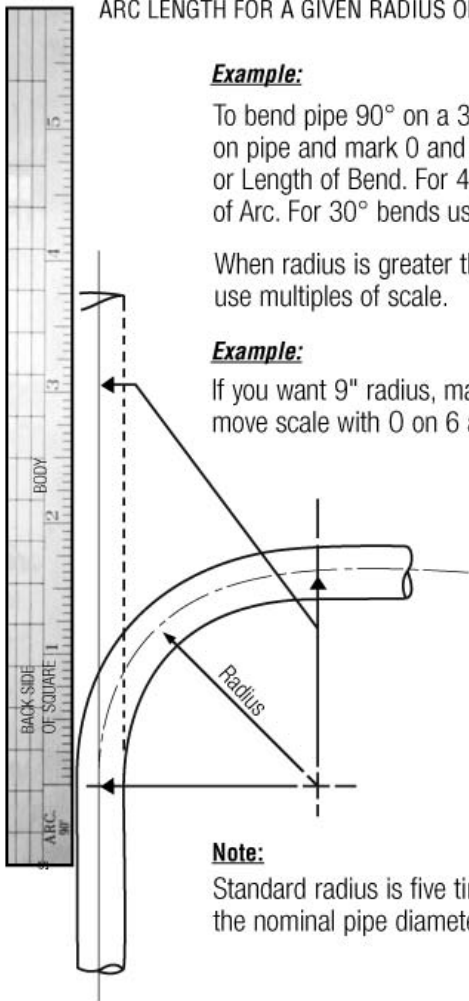

**Note:**

Standard radius is five times the nominal pipe diameter.

## CHART NO. 22

### TO ESTABLISH 1/4" MARKS ON PIPE

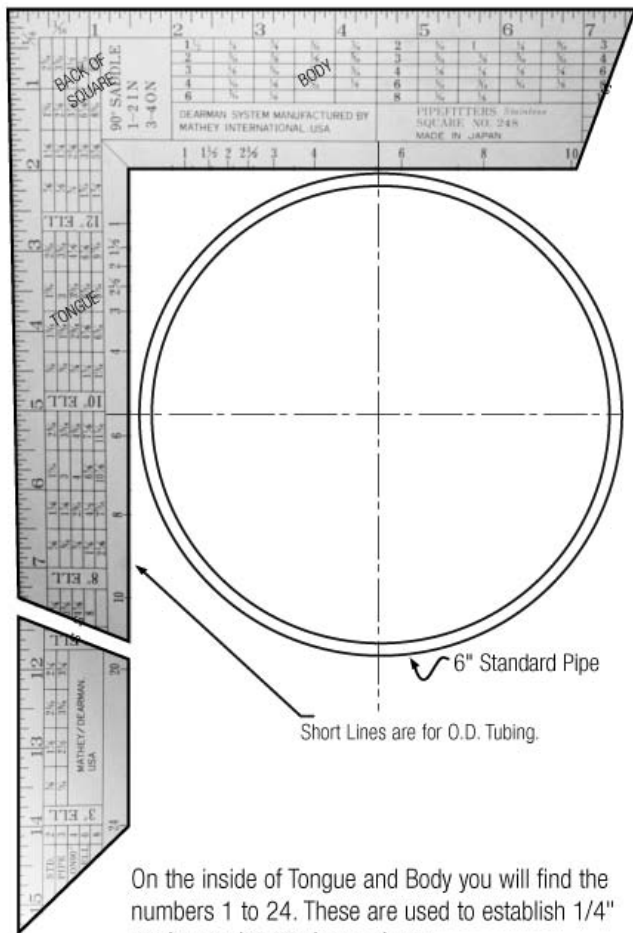

## EXAMPLE NO. 1

### FINDING CUT-BACK FOR ANY MITER.

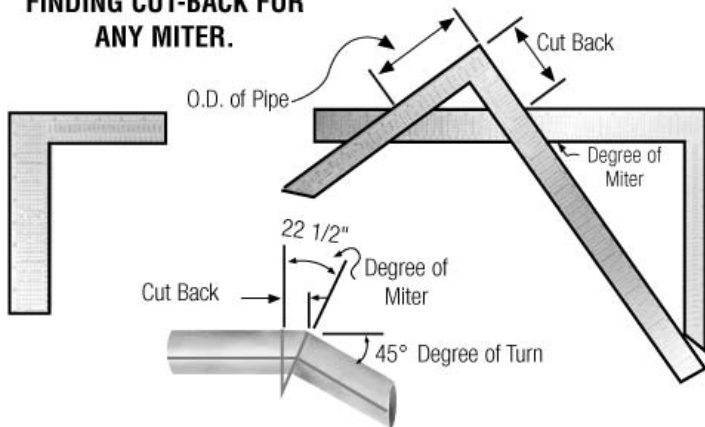

This scale is calibrated in Degree and 1/4 Degree.

**Note:** Degree of miter = 1/2 Degree of turn.

## EXAMPLE NO. 2

### TO CONVERT SLOPE IN INCHES PER FOOT TO DEGREE

Lay squares as shown with scales touching. Read Degree opposite given inch mark. This will be Degree of Slope.

Slope = 2" per 1'- 0"  
The Degree = 9 1/2°

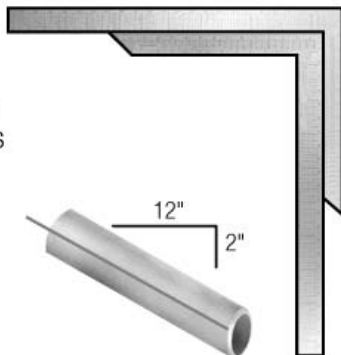

### EXAMPLE NO. 3

#### LAYING OUT LATERALS

When Branch and Header are the same size, the miter cuts may be taken directly from the square.

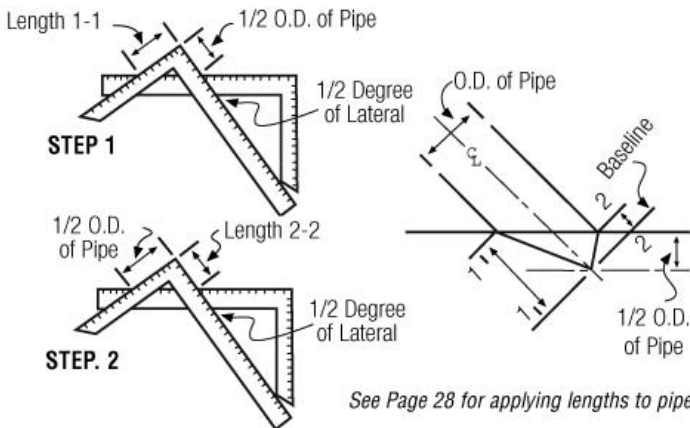

### EXAMPLE NO. 4

#### SOLVING TRIANGLES OR OFFSETS

Travel may be found by measuring across run and set.

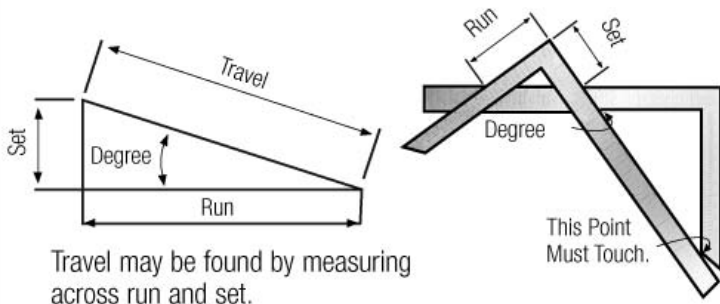

## EXAMPLE NO. 5

### LAYING OUT LATERALS

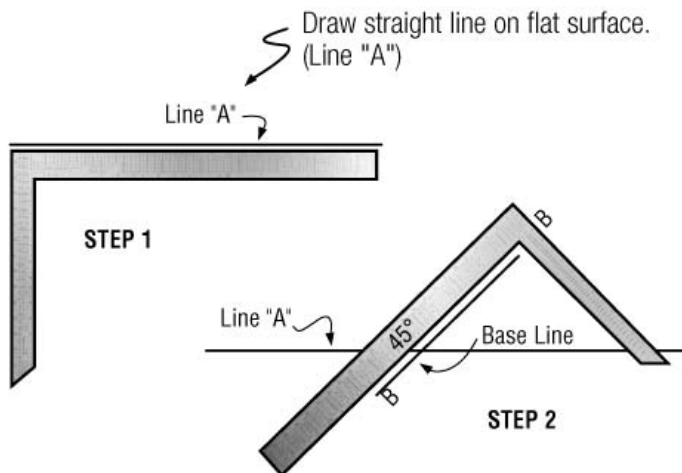

Then Set tongue on zero.  
Set Body on desired Degree  
of Lateral. Draw Base Line.  
(Line B)

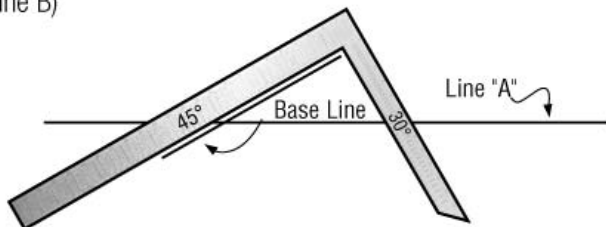

If degrees is greater than 45°; set Body on 45° and set Tongue  
on 90°. Minus the Degree of Lateral.

**Example:** For 60° lateral - 90° minus 60°; set Tongue on 30°.

## EXAMPLE NO. 5

Continued

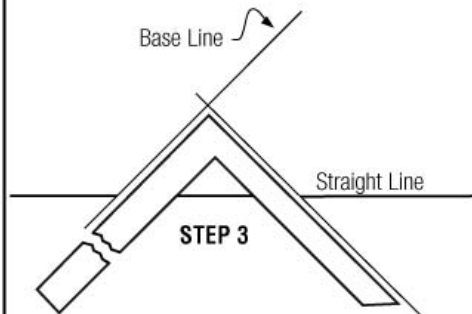

Set on nominal pipe.

**Example:** 6" pipe, set body on 6" mark.

Draw line "C" along Tongue of Square.

Move down to half the nominal pipe size.

**Example:** " 1/2" of 6" = 3".

Draw Center Line D along Tongue.

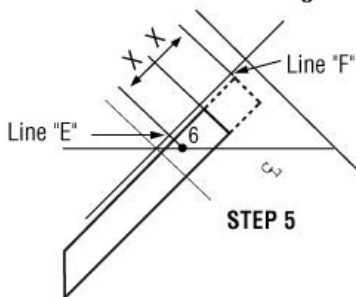
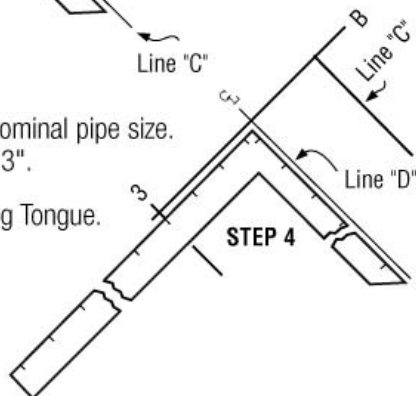

Place Body (Face Side) of square along Base Line. Place end along Center Line.

Mark off 6 (for 6" pipe), making line "E" for line "F". Move 6 to match Center Line.

Mark on end of square.

Use chart No.14.

"X" Dimensions of Standard Pipe.

## EXAMPLE NO. 5

Continued

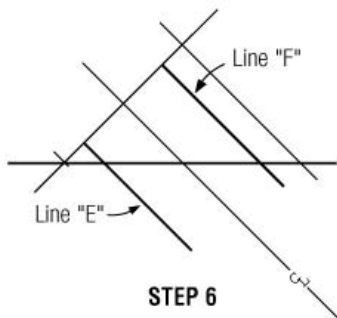

STEP 6

Place Body of Square along Base Line and mark lines off at "X" Points, thus making lines "E" and "F".

Using 90° Saddle Table on the Back Side, place body of square parallel with "A". Use dimension 3 on table.

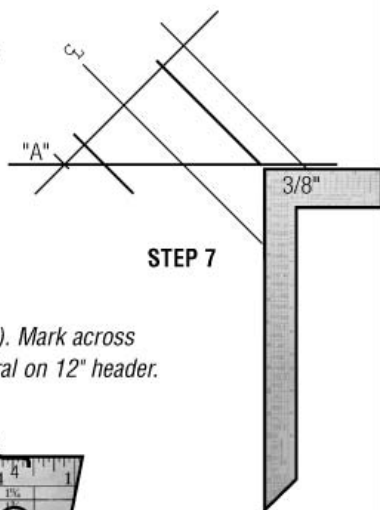

STEP 7

**Example:** See figure 1 (bottom). Mark across lines "E" & "F" at 3/8" for 6" lateral on 12" header.

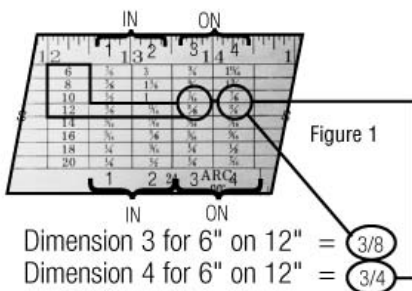



## EXAMPLE NO.5

Continued

Using same 6" on 12" use dimension 4 (Refer to Figure 1, Page 21) on 90° Saddle table. Place Body of Square parallel with line "A" and mark across center line (Line "D" at 3/4).

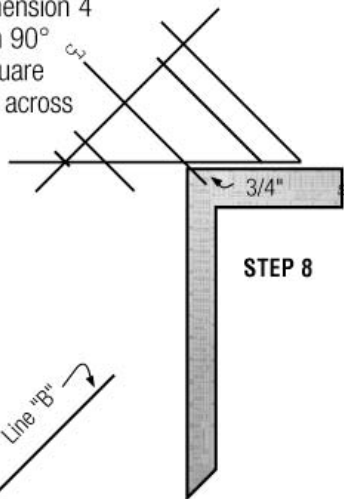

STEP 8

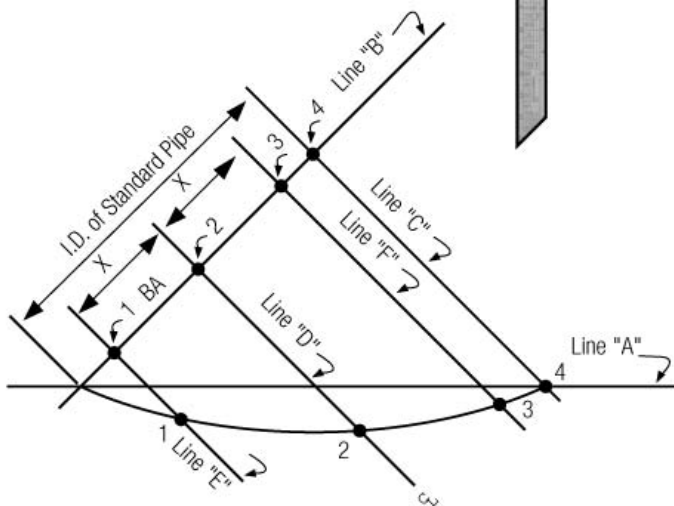

FINAL

1-1, 2-2, 3-3, 4-4, are Ordinate Lengths.

See Page 27 for applying lengths to pipe. All cuts are radial.

## EXAMPLE NO. 6

### FOR PARALLEL PIPING TO FIND MEASUREMENT "B"

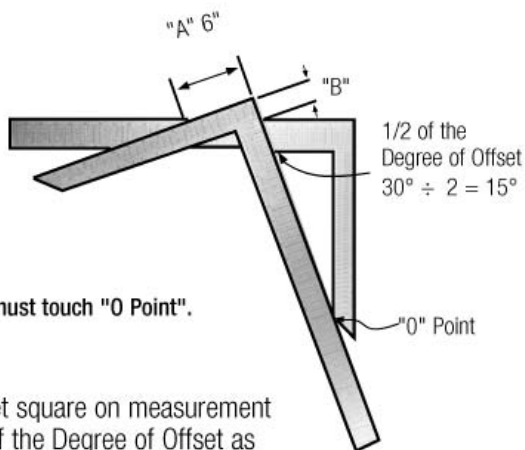
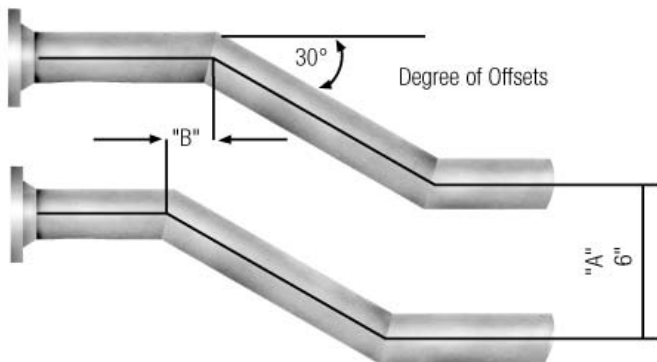

**Note:** Squares must touch "0 Point".

To find "B", set square on measurement "A" and 1/2 of the Degree of Offset as shown. Read "B" as shown.

## EXAMPLE NO. 7

### ROLLING OFFSET

#### EXTRA:

To find length 7, measure across Lengths 2 and 4 on square. Degree 8 is found the same as Degree 6, except Length 7 is used in place of Length 4 and Length 1 is used in place of Length 3.

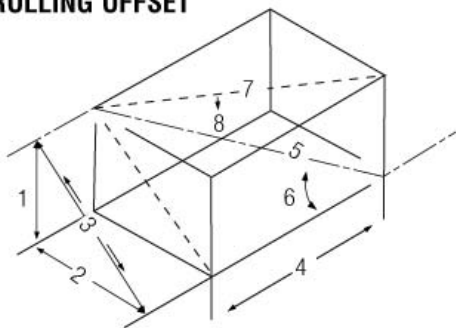

To find Length 5 and Degree 6, follow the steps below.

#### STEP 1

To find Length 3 measure across Lengths 1 and 2 as shown.

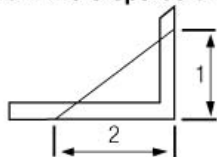

#### STEP 2

To find Length 5 measure across Lengths 3 and 4 as shown.

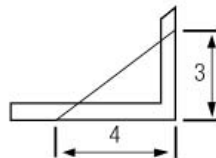

#### STEP 3

To find Degree arrange squares as shown.

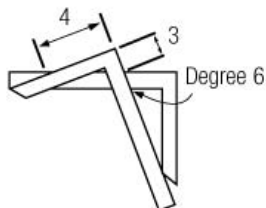

#### Note:

If Lengths are too long for squares, they may be scaled down.

**Example:**  $1'' = 1' - 0''$ ,  $1/12'' = 1''$  or  $3/4'' = 1' - 0''$ ,  $1/16'' = 1''$  etc.

See **Note 1** - page 25.

## SECOND METHOD

### FINDING LENGTH 5 AND DEGREE 6

#### Example:

If 4 = 19' 1" and 3 = 14' 6" use Face of Square which is divided into inches and twelfths, each inch = 1 foot, each twelfth = 1 in.

So, 19 1/12" would be 19' 1" and 14 6/12" would be 14' 6".

Measure across 3 and 4 to find 5. To find Degree 6 use second square as shown, with 45° mark in line with 19' 1" mark, read Degree 6 as shown.

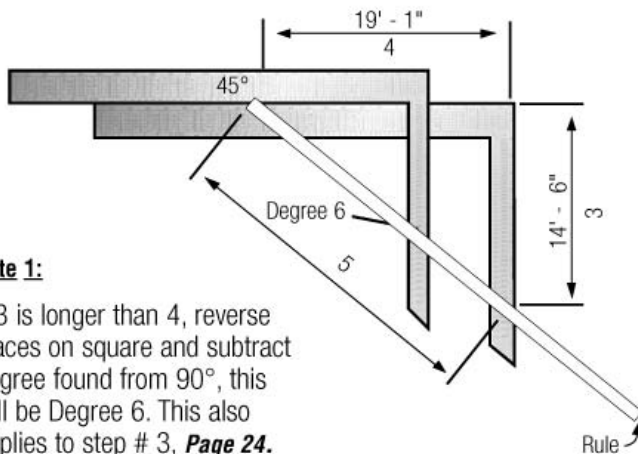

#### Note 1:

If 3 is longer than 4, reverse places on square and subtract degree found from 90°, this will be Degree 6. This also applies to step # 3, **Page 24.**

**Note 2:** See Page 9 for converting sixteenths to twelfths.

## EXAMPLE NO. 8

### PREPARING PIPE FOR ORDINATE LENGTHS



#### STEP 1

**FIRST:** Establish Base Line around pipe far enough from end of pipe to allow for longest Ordinate Length.

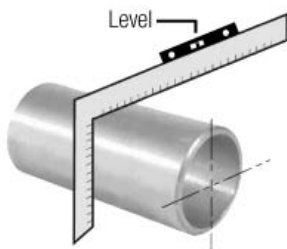

#### STEP 2

**SECOND:** Establish 1/4 marks on pipe, using 1/4 mark scale, found on the Back Side of square.

#### STEP 3

**THIRD:** Mark off 1/8 points using scale circumference 1/8 circumference found on Body of Square (face - side).



#### STEP 4

**FOURTH:** Mark Ordinate Lines using angle iron for straight edge.

## EXAMPLE NO. 9

### APPLYING ORDINATE LENGTHS TO PIPE

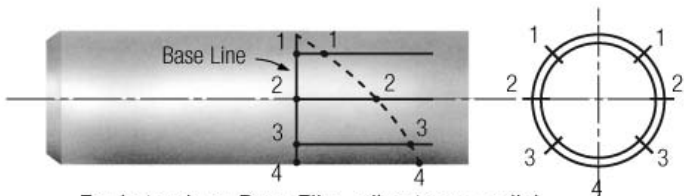

For Laterals or Base Ells - all cuts are radial.

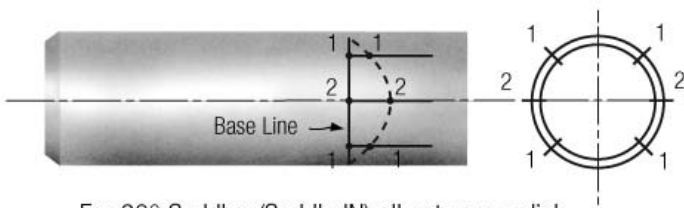

For 90° Saddles (Saddle IN) all cuts are radial.

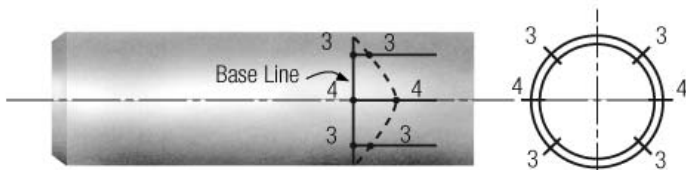

For 90° Saddles (Saddle ON) all cuts are radial.

**Note:** Dotted lines indicate line of cut.

## EXAMPLE NO. 10

### APPLYING ORDINATE LENGTHS TO PIPE

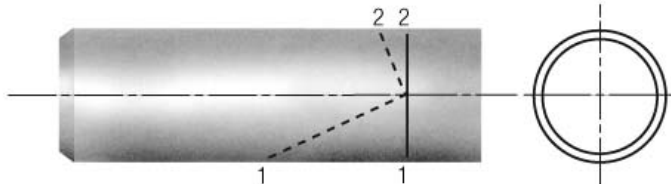

For laterals (Miter Method) all cuts are miter.

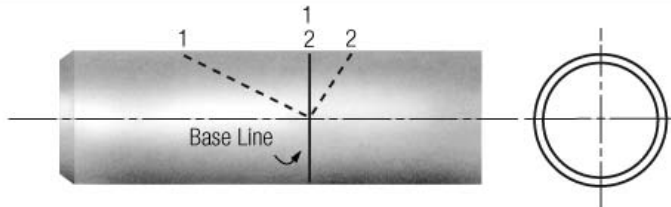

Hole layout for lateral (Miter Method) all cuts are miter.

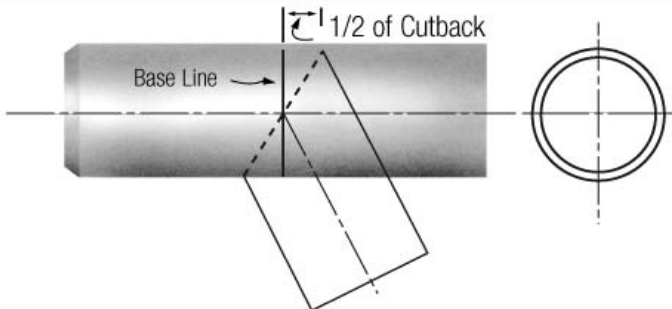

Layout for Miter Turn. All cuts are miter.

#### **Note:**

Dotted lines indicate lines of cut. Dash lines show position after fabrication.

### EXAMPLE NO. 11

#### TO FIND CENTER TO END OF BENDS OR FITTINGS

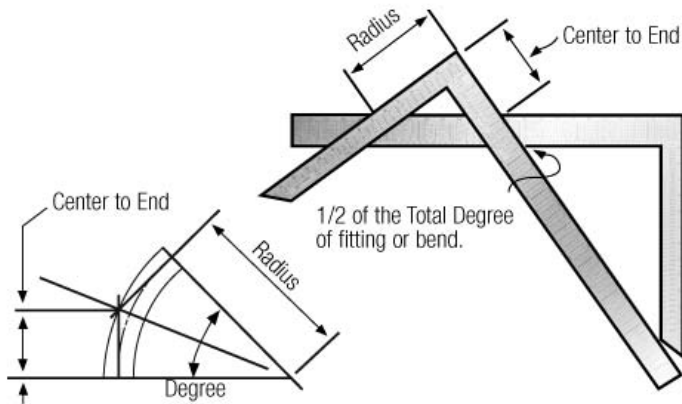

### EXAMPLE NO. 12

#### LAYING OF ANGLES

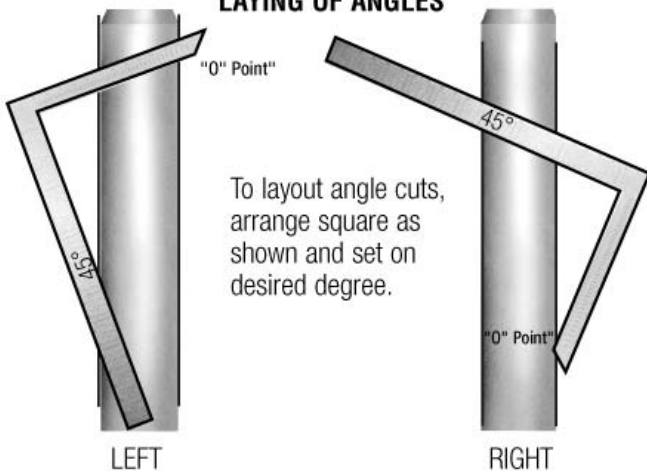



## EXAMPLE NO. 13

### LAYOUT OF A TRUE Y

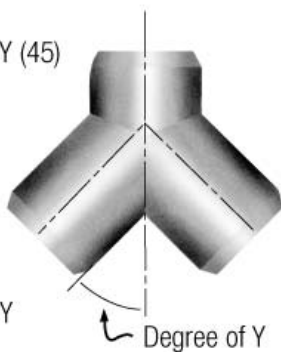
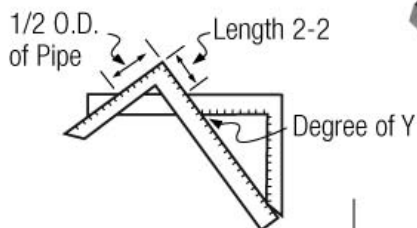
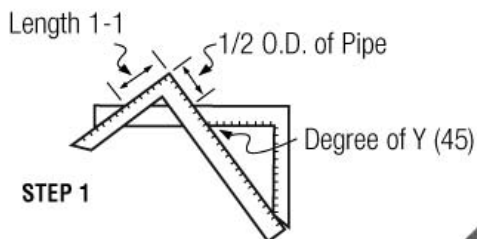

**STEP 2**

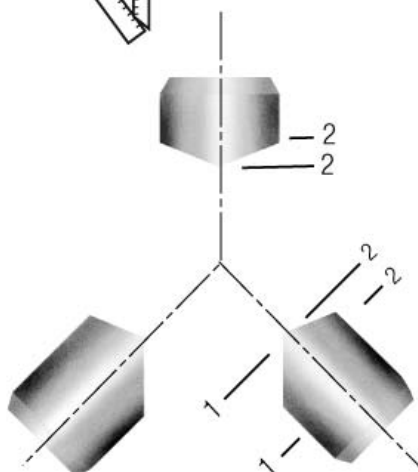

All cuts are miter.

The Mathey Dearman Pipefitter's Square may be used to determine:

- Squareness of one point in relation to another.
- Pipe centerline.
- Bolt length and diameter for flanges.
- The number of bolt holes required for a particular size flange and pipe circumference.
- Center to end dimensions on pipe elbow and tees.
- Length through hub of flange.
- Outside diameter of weld neck flange.
- Arc length for a given radius.
- Used with level to measure angles off horizontal or off vertical.

Square is marked in pipe fittings and pipe cuts instead of carpenter cuts.

Contains information to make or measure:

- Arcs
- Angles
- Tangents
- Diagonal Joints
- Y Joints
- Miters
- Saddles

Mathey Dearman, Inc.  
4344 S. Maybelle Ave.  
Tulsa, OK USA 74107  
(918) 447-1288  
Fax: (918) 447-0188  
E-mail: [sales@mathey.com](mailto:sales@mathey.com)  
<http://www.mathey.com>

C.I.A. Mathey Italiana, s.r.l.  
Via Isonzo, 26  
20050 San Damiano di Brugherio (MI)  
Italy  
Phone: (39) (039) 831019-2020021  
Fax: (39) (039) 2020079  
E-mail: [ciamathey@promo.it](mailto:ciamathey@promo.it)  
<http://www.ciamathey.com>

